

Installation and maintenance instructions for GRAF rainwater storage tank Carat XL

8.500 L Order No. 370005
10.000 L Order No. 370006



The points described in these instructions must be observed under all circumstances. All warranty rights are invalidated in the event of non-observance. Separate installation instructions are enclosed in the transportation packaging for all additional articles purchased from GRAF.

The tank must be checked for any damage prior to insertion into the trench under all circumstances.

Missing instructions can be downloaded on www.graf.info or can be requested from GRAF.

Table of contents

1. GENERAL NOTES	11
1.1 Safety	11
1.2 Identification obligation	11
2. INSTALLATION CONDITIONS	12
3. TECHNICAL DATA	13
4. TANK STRUCTURE	14
5. INSTALLATION AND ASSEMBLY	14
5.1 Construction site	15
5.2 Trench	15
5.3 Insertion and filling	16
5.4 Routing connections	16
6. ASSEMBLING THE TANK DOME AND TELESCOPIC DOME SHAFT	17
6.1 Assembling the tank dome	17
6.2 Assembling the telescopic dome shaft	17
6.3 Telescopic dome shaft on which persons may walk	17
6.4 Telescopic dome shaft over which passenger cars may drive	17
6.5 Truck telescopic dome shaft	18
6.6 Assembling the adapter	18
7. INSPECTION AND SERVICING	18

1. General notes

1.1 Safety

The relevant accident prevention regulations according to BGV C22 must be observed during all work. Particularly when walking on the tanks, a 2nd person is required to secure the tank.

The relevant regulations and standards must additionally be taken into consideration during installation, assembly, servicing, repair, etc. Relevant notes can be found in the corresponding sections of these instructions.

During all work on the system or parts of the system, the entire system must always be rendered inoperable and secured to prevent unauthorised reactivation.

Except in the event of work carried out in the tank, the cover of the tank must always be kept sealed, as this otherwise constitutes a maximum risk of accident. The rain protection installed on delivery is merely transportation packaging. It cannot be walked on and is not child-proof; it must be replaced with a suitable cover immediately following delivery (telescopic dome shaft with corresponding cover)! Only original GRAF covers or covers approved in writing by GRAF must be used.

GRAF offers an extensive range of accessories, all of which are designed to match each other and which can be extended to form complete systems. The use of other accessories may lead to impediments to the system's functional capability, therefore invalidating liability for resulting damage.

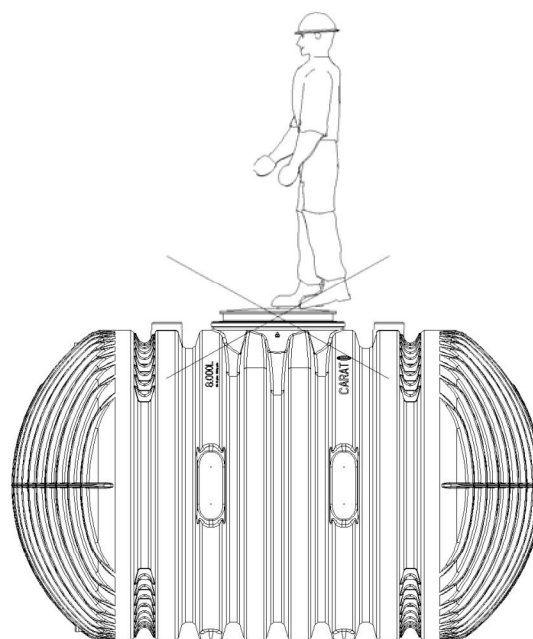

1.2 Identification obligation

All service water pipes and outlets must be identified in writing with the words **"Not drinking water"** or in the form of images (DIN 1988 Part 2, Para. 3.3.2.) in order to avoid inadvertent connection with the drinking water mains even after a number of years. Mix-ups, e.g. by children, may still occur even in the case of correct identification. All service water extraction points must therefore be installed with valves with **child-proof locks**.

2. Installation conditions

Covering heights with telescopic dome shaft in green areas

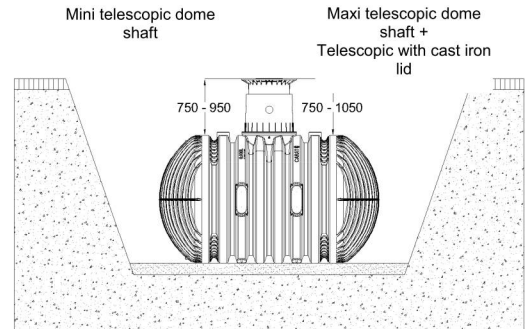

Max. covering heights with extension and telescopic dome shaft

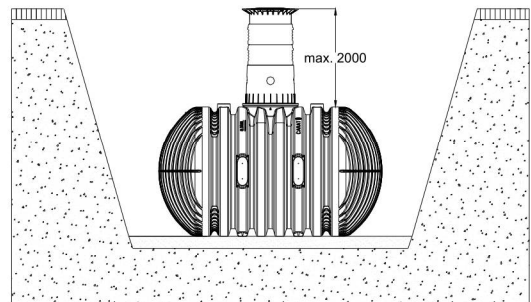

Covering heights with cast telescopic dome shaft (with class B cast cover) in areas with car traffic (load up to 3.5 t).

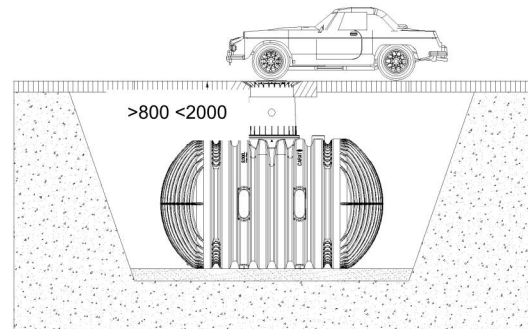

(without ground water and stratum water)

Covering heights with truck telescopic dome shaft (with Class D cover to be provided by customer) in areas with truck traffic (load up to 12 t, without ground water and stratum water).

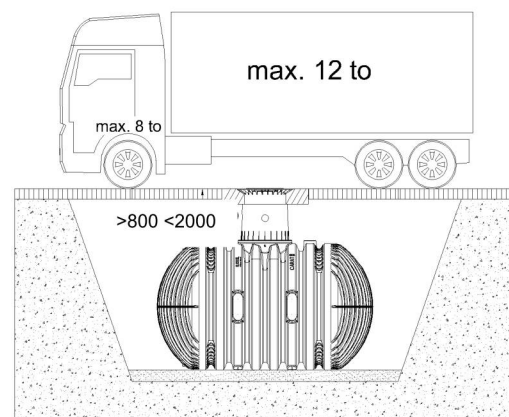

The tanks can be only partially installed into the groundwater. If it is to be expected that the ground water could rise higher, even occasionally, as shown in the figure opposite.

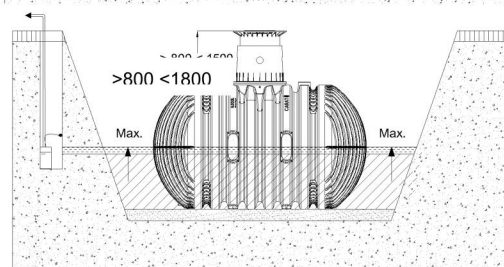

3. Technical data

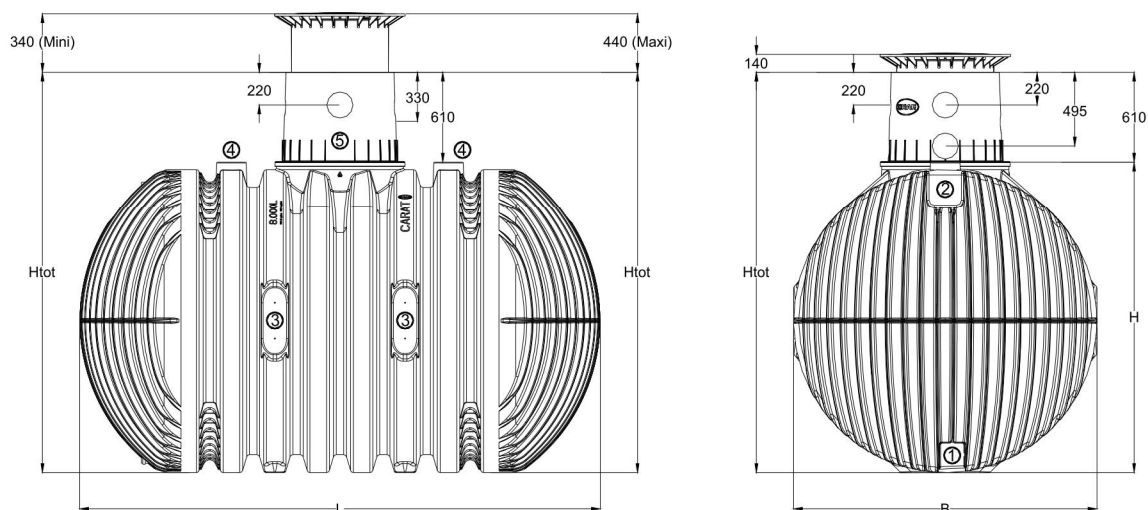

Tank	<u>8.500 Litre</u>	<u>10.000 Litre</u>
Art. No.	370005	370006
Weight	380 kg	456 kg
L	3500 mm	3520 mm
B	2040 mm	2240 mm
H	2085 mm	2285 mm
Htot** *Htot – total height	2695 mm	2895 mm

<u>Connecting faces</u>	<u>DN100</u>	<u>DN150</u>	<u>DN200</u>
① Tank bottoms (underneath)	2-off		
② Tank bottoms (top)		2-off	
③ Tank cylinder (sides)	8-off		
④ Tank cylinder (top)			2-off
⑤ Tank dome		5-off	

4. Tank structure

① Cover

② Telescopic dome shaft (can be inclined by 5°)

③ Profile seal

④ Tank dome (rotating through 360°)

⑤ Tank - tank dome seal

⑥ Carat XL underground tank

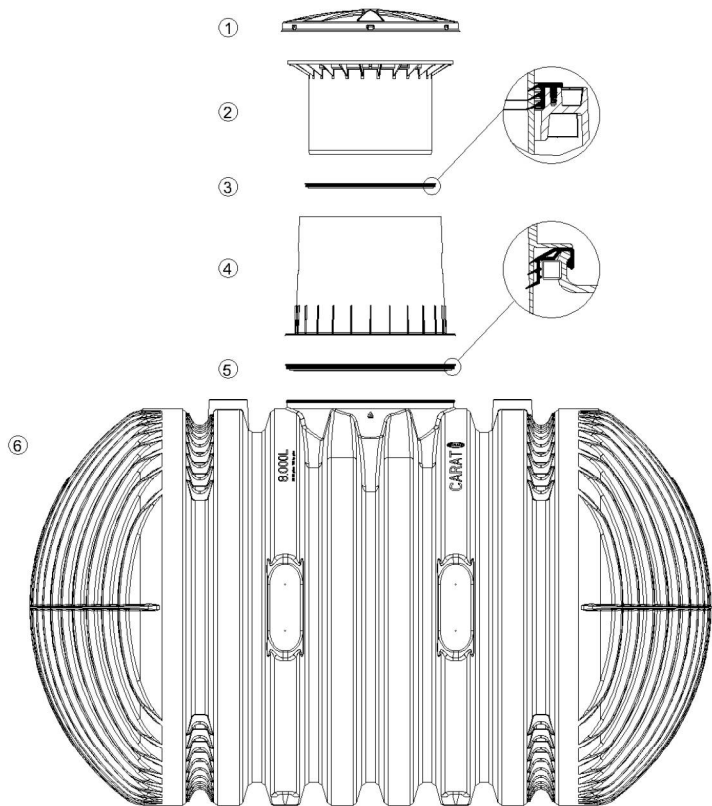

5. Installation and assembly

① Subsoil

② Telescopic dome shaft

③ Compacted foundation

④ Surrounding (round-grained gravel, max. grain size 8/16)

⑤ Covering layer

⑥ Underground tank Carat XL

⑦ Concrete layer for surfaces used by senger cars / trucks

β according to DIN 4124

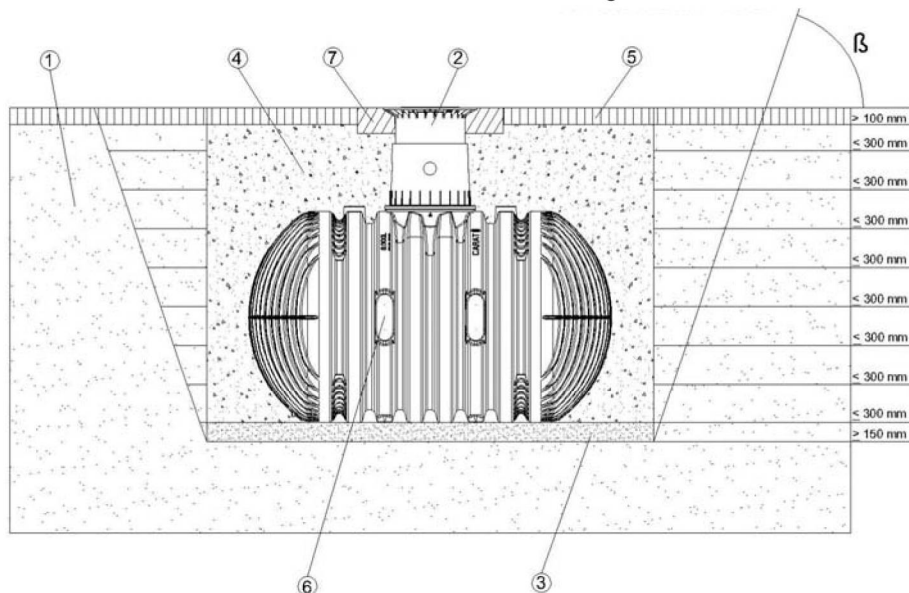

5. Installation and assembly

5.1 Construction site

Under all circumstances, the following points must be clarified prior to installation:

- The structural suitability of the ground according to DIN 18196
- Maximum groundwater levels which occur and drainage capability of the subsoil
- Types of load which occur, e.g. traffic loads

An expert ground report should be requested from the local planning authority to determine the physical characteristics of the subsoil.

5.2 Trench

To ensure that sufficient space is available for working, the base area of the trench must exceed the dimensions of the tank by 500 mm on each side; the distance from solid constructions must be at least 1000 mm. The embankment must be designed according to DIN 4124. The construction site must be horizontal and plane and must guarantee sufficient load-bearing capacity.

The depth of the trench must be dimensioned so that the max. earth coverage (see point 2 – installation conditions) above the tank is not exceeded. To use the system throughout the entire year, it is necessary to install the tank and those parts of the system which conduct water in the frost-free area. The frost-free depth is usually approx. 600 mm – 800 mm; precise information in this regard can be obtained from the responsible authority.

A layer of compacted, round-grain gravel (grain size 8/16, thickness approx. 150 - 200 mm) is applied as the foundation.

5.2.1 Slope, embankment, etc.

On installation of the tank in the immediate vicinity (< 5 m) of a slope, earthen mound or slope, a statically calculated supporting wall must be erected to absorb the soil pressure. The wall must exceed the dimensions of the tank by at least 500 mm in all directions, and must be located at least 1000 mm away from the tank.

5.2.2 Groundwater and cohesive (water-impermeable) soils (e.g. clay soil)

With only occasional ground water and cohesive, water-impermeable soils (e.g. loam), adequate drainage of the ground water or leakage water must be ensured so that the

tanks never stand deeper in the ground water than indicated in the table. If necessary, the drainage line must end in a vertical DN 300 pipe in which an immersion pressure pump is installed to pump off the excessive water. The pump must be checked at regular intervals.

If it is to be expected that the tanks could sink lower, adequate drainage must be ensured in all cases.

We recommend the general laying of a drainage line, since in the event of prolonged rainfall the ground water level can rise unexpectedly.

5.2.3 Installation adjacent to surfaces used by vehicles

If the underground tanks are installed adjacent to surfaces which are used by heavy vehicles weighing over 12 t, the minimum distance away from these surfaces is at least the depth of the trench.

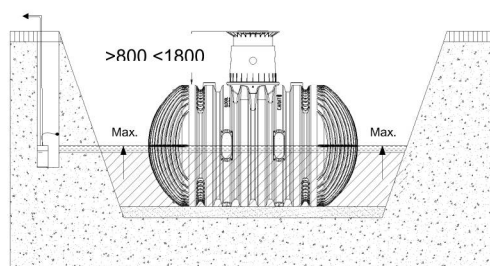
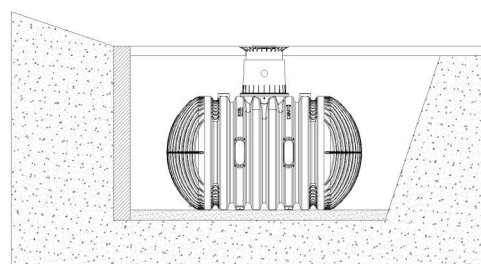

Tank size	8.500 L	10.000 L
Immersion depth	1042,50 mm	1142,50 mm

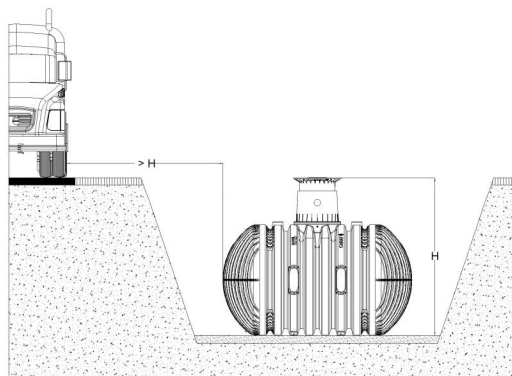

5. Installation and assembly

5.2.4 Connection of several tanks

Two or more tanks are connected via the assembly surfaces by means of GRAF special seals DN 100 and basic pipes (to be provided at construction site).

The apertures must be drilled to the corresponding size using only the GRAF special crown bit. It must be ensured that the distance between the tanks is at least 600 mm. The pipes must project 100 mm - 150 mm into the tanks.

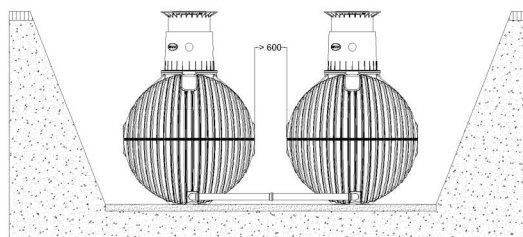

5.3 Insertion and filling

The tank must be inserted, impact-free, into the prepared trench using suitable equipment. The tank is filled with approx. 25 cm water before filling the tank surround.

Afterwards the surrounding (roundgrain gravel, max. grain size 8/16) is then filled in layers of max. 40 cm steps and is compacted.

The individual layers must be well-compacted (manuel tamper). Damage to the tank must be avoided during compaction. Mechanical compaction machines must not be used under any circumstances. The surrounding must be at least 500 mm wide.

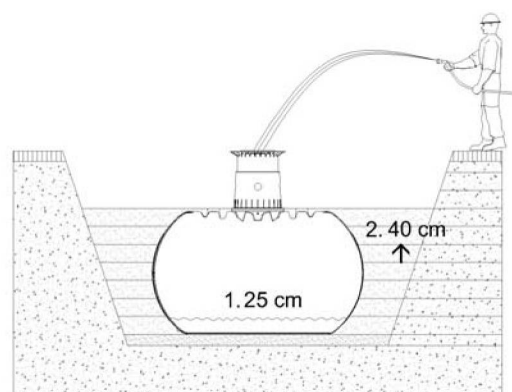

5.4 Routing connections

All feed and overflow pipes must be routed with a decline of at least 1% in the direction of flow (possible, subsequent settling must be taken into consideration in this case). If the tank overflow is connected to a public sewer, this must be protected against reflux by means of a lifting station (mixed sewer) or reflux seal (pure rainwater sewer) according to DIN 1986.

All suction, pressure and control lines must be routed in an empty pipe, which must be routed as straight as possible, without bending, to the tank with a decline. Necessary bends must be formed using 30° moulded sections.

Important: The empty pipe must be connected to an aperture **above** the max. water level.

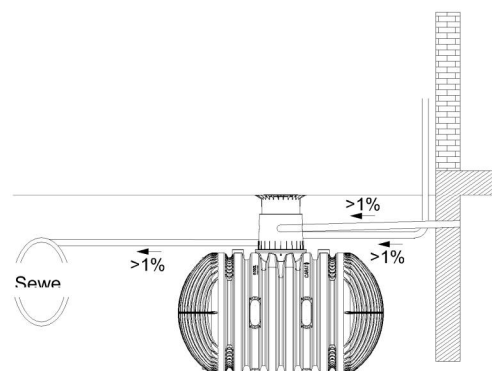

6. Assembling the tank dome and telescopic dome shaft

6.1 Assembling the tank dome

Prior to assembly, the enclosed seal is locked onto the tank neck's profile „B“. The tank dome is then aligned with the piping connections and is locked to the tank neck. It is essential to make sure that the upper seal "A" (pre-assembled) is correctly installed.

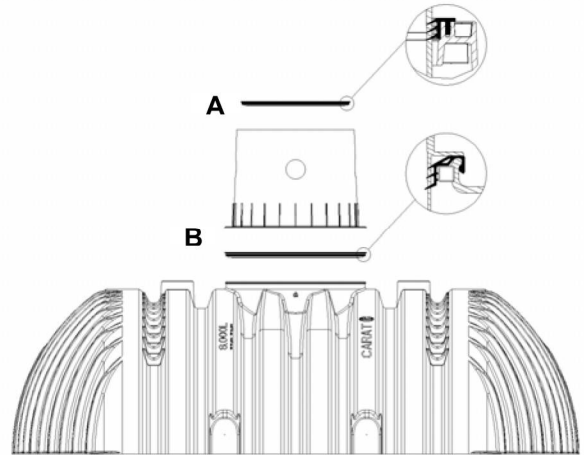
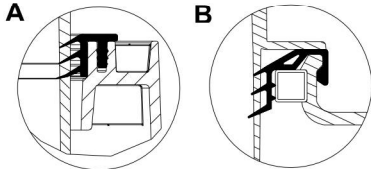

6.2 Assembling the telescopic dome shaft

The telescopic dome shaft enables infinite adaptation of the tank to given site surfaces with earth coverage of between 750 mm and 950 mm (Mini telescopic dome shaft) or 750 mm and 1050 mm (Maxi telescopic dome shaft).

For assembly purposes, the enclosed profile seal (material EPDM) is inserted into the tank dome's sealing groove and is coated generously with soft soap (do not use mineral oil-based lubricants, as these attack the seal). The telescope is then greased, inserted and aligned with the surface of the site.

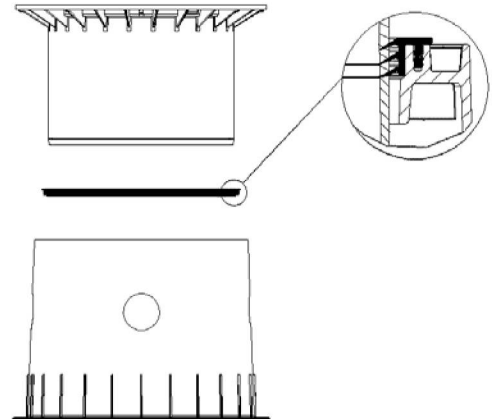

6.3 Telescopic dome shaft on which persons may walk

Important: To prevent loads from being transferred onto the tank, round-grain gravel ② (max. grain size 8/16) is filled in in layers around the telescope ① and is evenly compacted. Damage to the tank dome ③ and telescope must be avoided during this step. The cover is then positioned and is sealed to prevent entry by children. **Tighten the threaded connection on the cover so tightly that it cannot be opened by a child!**

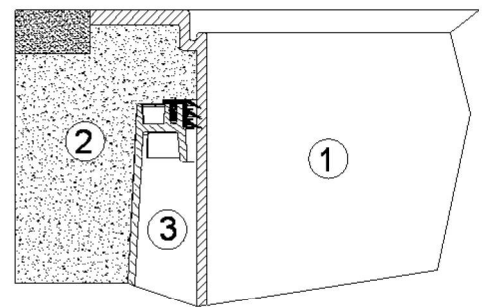

6.4 Telescopic dome shaft over which passenger cars may drive

If the tank is installed under areas used by passenger cars, the collar area of the telescope ① (colour anthracite) must be supported with concrete ④ (load class B25 = 250 kg/m²). The layer of concrete to be installed must be at least 400 mm wide and approx. 200 mm high all around. The minimum coverage above the shoulder of the tank is at least 800 mm (max. 1050 mm with telescope, coverage up to max. 1800 mm possible with intermediate section).

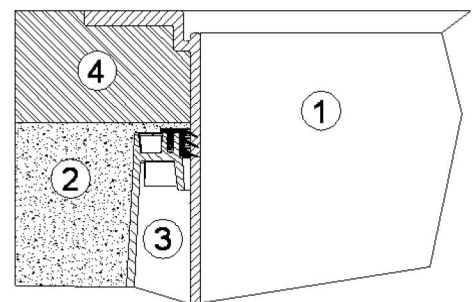

Attention: It is essential to use the cast telescopic dome shaft (with class B cast cover).

6. Assembling the tank dome and telescopic dome shaft

6.5 Truck telescopic dome shaft

On installation under areas used by trucks with a maximum weight of 12 t, the telescope ① is supported as described in point 6.4. The concrete rings ⑥ (Ø 600 mm) and a cast frame ⑤ with star-shaped load distribution for mounting the cast cover are then installed (observe earth coverage of at least 800 mm, max. 1800 mm). The cast frame must have a supporting area of approx. 1 m².

Attention: It is essential to use the truck telescope dome shaft (class D cover to be provided by customer).

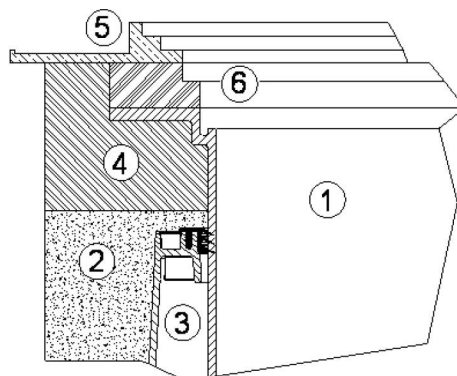

6.6 Assembling the adapter

For larger coverage heights an adapter is needed. To insert the adapter into the tank dome, soft soap is needed. Into the highest groove of the adapter the profile seal is inserted and greased generously. Afterwards push the telescopic dome shaft into the adapter and adapt it to the planned area surface.

max. earth-cover 1800 mm

(in each case in connection with the Maxi telescopic dome shaft)

- ① Telescopic dome shaft (can be inclined by 5°)
- ② Adapter
- ③ Tank dome (can be rotated by 360°)

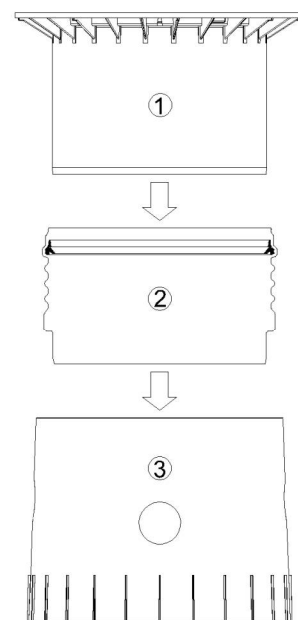

7. Inspection and servicing

The entire system must be checked for leaks, cleanliness and stability at least every three months.

The entire system should be serviced at intervals of approx. 5 years. In this case, all parts of the system must be cleaned and their function checked. Servicing should be carried out as follows:

- Drain the tank completely
- Clean surfaces and internal parts with water
- Remove all dirt from the tank
- Check that all internal parts are firmly seated.